

## IMPROVING PRODUCTIVITY IN FEED MIXING MACHINE MANUFACTURING IN NIGERIA

**Engr.Rufus Ogbuka Chime ,MNSE, MNimechE,**  
Institute of Management and Technology (IMT)  
Enugu, Enugu.  
E-mail;rumechservices@yahoo.com

**Engr.Samuel I.Ukwuaba, FNSE FNIMEchE,**  
**Petroleum Training Institute**  
Effurun Delta State.  
E-mail.ukwubasamuel@gmail.com

**Engr,Benedict.N Ugwu MNSE MNimechE**  
Enugu State University of Science and Technology  
Enugu, Enugu State  
Email: bnugwu@yahoo.com

**Prof.Abdulrahim Abdulbaqi Toyin, MNSE**  
**University of Maiduguri**  
Maiduguri,Borno.  
E-mail;engrabdulrahimat@gmail.com

**Anthony Igwe PhD,MSc,MNIM**  
Department of management  
Faculty of Business Administration  
University of Nigeria  
Enugu campus  
E-mail;anthonyigwe121@yahoo.com

**Benjamin Ibe ChukwuPhD,MIRD,FIIA**  
Department of Management  
Faculty of business Administration  
University of Nigeria  
Enugu Campus  
E-mail;benjaminichukwu@yahoo.com

### ABSTRACT

The idea of mixing various feed materials such as grains, feed supplements and other animal feeds to produce a homogenous mix ready for dispensing for animal consumption had been part of man's activities since the creation of man. This has always been done using crude methods such as hands, sticks etc. In this recent time, the advancement in technology has brought about the use of machines to perform the same function much faster, accurately and with less energy consumption. It is for this purpose that the feed mixing machine has been designed. The scope of this project is to design a small feed mixing machine, to model and simulate the machine before production, to fabricate components of the feed mixing machine based on design specifications and to test the machine after fabrication, while in designing and in material selection consideration was given to the techno-economic status of the micro scale industries who are intended users of the machine. Feed mixing machines are used in feed mills for the mixing of feed ingredients. The machine plays a vital role in the feed production process, with efficient mixing being key to good feed production. If feed is not mixed properly, ingredients and nutrients will not be properly distributed within a precise time. This means that the feed will not have even nutritional benefit and would be bad for the birds that are feeding on the feed. Feed mixing machines comprise of a frame structure, the mixing chamber (a cylinder and cone structure) where other components such as electric motor, shaft and hopper are mounted on. The mixing of feed to form a uniform ration is a regular need on large stock poultry purposes. The mixing is performed by a vertical shaft which revolves continuously in a cylindrical cone suspended by an iron bar. The relative motion of the shaft about the frame (body) is achieved by the use of knuckle bearing. Mixing is done in the mixing chamber. The mixer is constructed to take a capacity of 30kg, but the excess capacity of 40kg was provided to take care of overloading. This machine was powered by 3hp power motor.

Product Lifecycle manufacturing (PLM) is redefining the use of information throughout the product lifecycle and specifically, as discussed here, in the manufacturing phase of the product's lifecycle. Product manufacturers need to consider manufacturing two products: the physical products that they have always produced and the virtual product that is the information about the physical product. This virtual product can provide manufacturers with a new source of value. After thoroughly researching, designing and experimenting with software's final machine was developed optimizing the process, the product time was successfully reduced from several hours to 5 minutes. All other engineering and customer design requirements were met, through the success of the design.

**Key words: Design process. Sustainability. Productivity and Management**

### LITERATURE REVIEW

The beginning of industrial scale production of animal feeds can be traced back to the late 1800s, this is around the time that advance in human and animal nutrition was able to identify the benefits of a balanced diet, and the importance or role the processing of certain raw materials played in this. Corn gluten feed mixer was first manufactured in 1882, while leading world feed producer Purina feeds was established in 1894 by William H Danforth. Cargill which was mainly dealing in grains from its beginning in 1865, started to deal in feed mixer production at about 1884. The feed industry expanded rapidly in the first quarter of the 1900s with "Purina" expanding its operations into Canada and opened its first feed mill in 1927. In 1908 Herbert Johnson, an engineer for the Hobart manufacturing company, invents an electric standing mixer. His inspiration came from observing a baker mixing bread dough with a metal spoon; soon he was toying with a mechanical counterpart. By 1915, his 80-quart mixer was standard equipment. In 1908 the feed industry was revolutionized by the introduction of the first feed mixer used for mixing pelleted feeds. Farmers still employ crude techniques for processing their products, for example, they still use hands to mix already crushed feeds, these crude techniques are not only labour intensive but also lead to slow level production of small quantities of feed.

. It could be cited that the poor quality products of feed could be as a result of improper mixing of feed. Again, large quantities of feed will be very difficult to mix by hand if not impossible, thereby producing poor quality products and reducing production rate. This lowers the profits margin of the products. On the other hand, the cost of importation of foreign machine for mixing feed is very high compared to the producer's mega resources. Generally, this affects the country's foreign reverse. Also it tends to bring down the cost of the machine to the reach of the small scale producers. Besides it creates employment opportunities for the farmers, this design was chosen for reliabilities..

- Long product development,
- Countless trial and error,
- Accountability
- Limited Profitability

The cost of machine of this type could be high when produced under small scale production. But the other advantages are that it does not require any specialist skill for its operation and it does not call for any elaborate production environment before it becomes operational and so many others. The advantages of this design

outweigh the disadvantages. In fact it can be used where mass production is necessary with high efficiency. The principal of operation is very simple one. The feed ingredient are placed between stationery drum and the rotating blades agitates the feeds which mixes the various feed ingredient as a result force between neighbouring feeds. Investigation shows that the few available small scales processing equipment are not very efficient This lack of efficient small scale processing equipment to farmers has increased the inability of their farming activities. It is general knowledge that those who are engaged in agriculture are poor in the comparison with those engaged in other sector of the economy in Nigeria that is to say their standard of living is so low. That shortage of funds to enable them purchase modern facilities has been a major handicap in the development of agriculture. Means of alleviating this problem is the provision of modern facilities made locally at cheaper rates This will lead to increased productivity in agriculture which could enable manufacturer and consumers to benefit from the supply of relatively cheaper and better produce at the right time and in sufficient quantity .For these demands to be met to maintain a sustainable economic growth in Nigeria a much higher production level in the agricultural sector is necessary through these use of design, modelling , simulation ,sustainability and Engineering management.

#### **COMPONENT AND MATERIAL SELECTION**

Most machine and tools are constructed from metallic and non-metallic materials. The metals are divided into two groups' ferrous metals: are those which have the iron as their main constituent such as cast iron, wrought iron and steel. Non-ferrous metals: are those which have a metal other than iron as their main constituent such as copper, aluminium, brass, tin, zinc etc.

The selection of a proper material, for engineering purposes, is one of the most difficult problems for the designer. The best material is one which serves the desired objective at the minimum cost. The following factors are considered while selecting the material:

- Availability of the materials.
- Suitability of the materials for the working conditions in service.
- The cost of the materials.

The machine (feed mixing machine) which has been produced from the assembly of various components were designed based on the properties of materials, including the frame, shaft, knuckle bearing, pulley and belt, mixing chamber (cylinder and cone structure) and

electric motor. The design considerations for each component are discussed below:-

**FRAME:** This component is the primary made up of mild steel fig; 15. The reason for this is that the material

**BELT AND PULLEY:** possessed the required properties as ductility, plasticity and also considerable strength which are capable of being fabricated to the required degree of functional tolerance. Also the selection factors are being cheap and most abundant in the market in case of replacement, machine ability or workable are other consideration.

they exist as standard components. The pulley can be made up of aluminium, cast iron and mild steel etc owing to the weight consideration of these materials mentioned above; we selected the cast iron pulley. This would help to reduce vibration of the shaft. On the other hand, the belt will be Vee-shaped fig4&,10. We choose the Vee-belt for our design with the following consideration:-

It is because of the pulley groove. It does not jump out while in motion. The vee-belt drive gives due to the distance between centres of pulleys. It provides longer life, 3 to 5 years. It can be easily installed and removed. The operation of the pulley and v-belt is quiet. Also, we prefer belt to chain because of alignment.

## DESIGN PROCESS

### MODELLING AND SIMULATION OF THE MACHINE / THE COMPONENTS

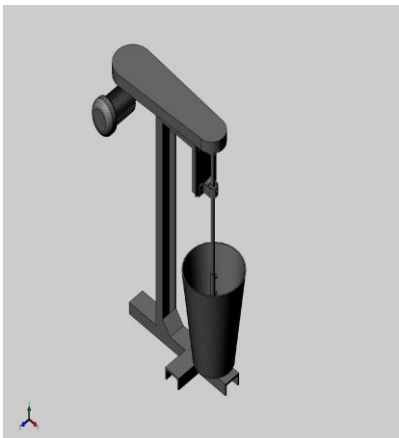

Fig.1 Final Design



Fi:2 Electric motor



Fig :3. cover

**MIXING CHAMBER (CYLINDER AND CONE STRUCTURE):** This is the mixing chamber of the machine. Fig 12 It is required to use mild steel metal sheet which are of considerable strength and which are capable of being fabricated to the required degree of functional tolerance are preferable used for reliability of operation and lessened frequency maintenance. Another reason for its use is because of its abundant in the market and weld ability.

**ELECTRIC MOTOR:** This is the source of power for the design. It exists in a standard component. It has single phase and three phase but for our design, we use the three phase. It has a three horse power (3hp) and the speed of the electric motor is 1500 rpm fig;2.

**SHAFT:** this is also made of mild steel besides the considerations mentioned above, we consider its toughness properties which can be improved through heat treatment.fig;7

**BEARING:** It exists as a standard component, it is of various types- cone bearing, roller, knuckle bearing and from steels-chromium steel. Among these types mention above, some are sealed while some are not. For our design, we opt for the knuckle bearing with sealed ball bearing to avoid grease contamination on the feed fig.11. The selection of knuckle bearing is that it balances itself and possesses the required hardness and toughness.

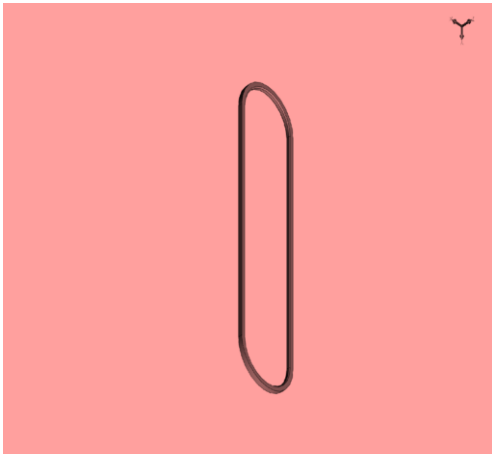

Fig :4 pulley  
stress

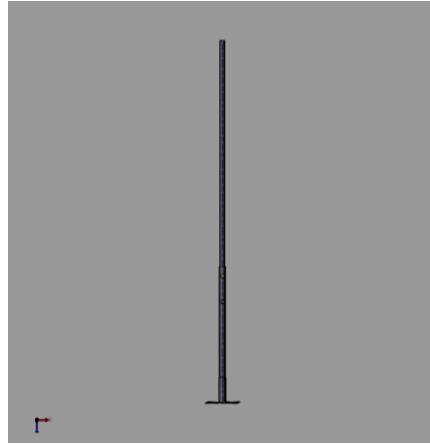

fig: 5 shaft



fig: 6 shaft under



Fig.7 simulation process

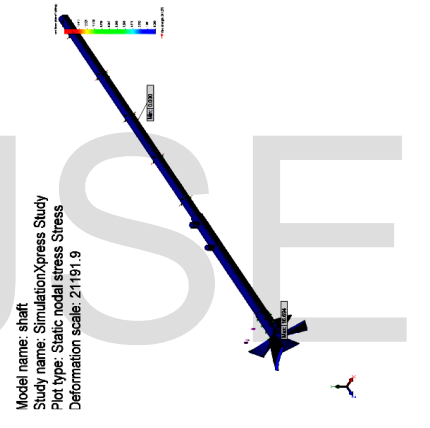

Fig .8 deform shape

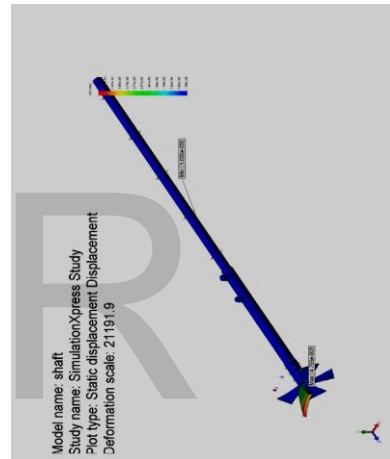

Fig: 9 factor of safety

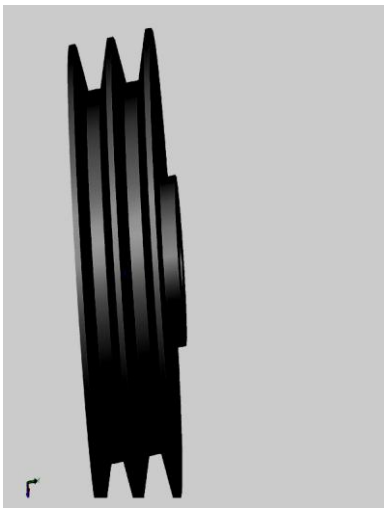

Fig.10 pulley

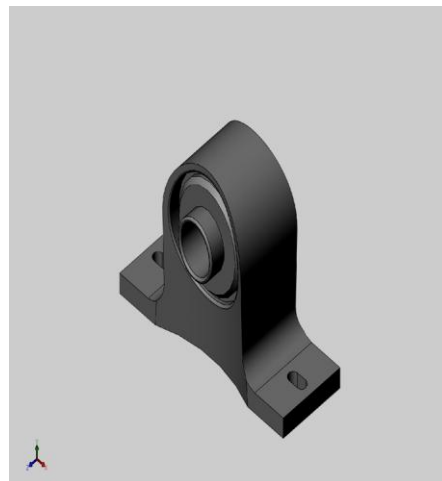

Fig.11 Bearing

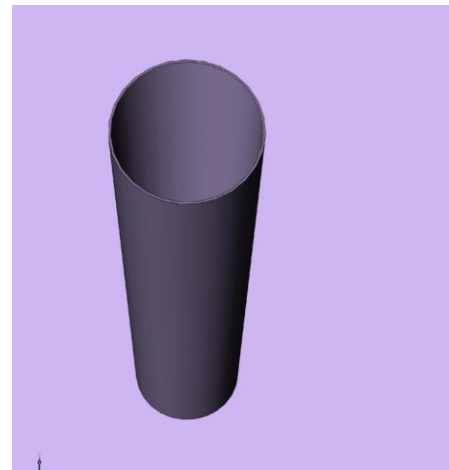

Fig .12 bucket

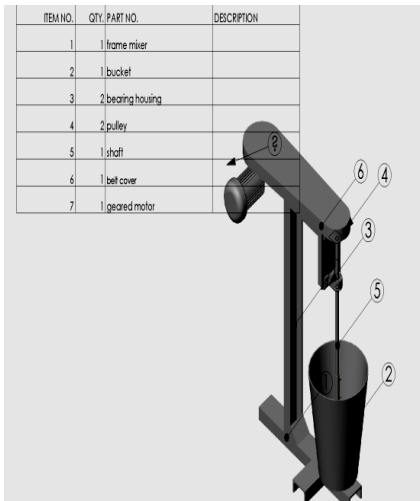

Fig 13. Detailed Drawing

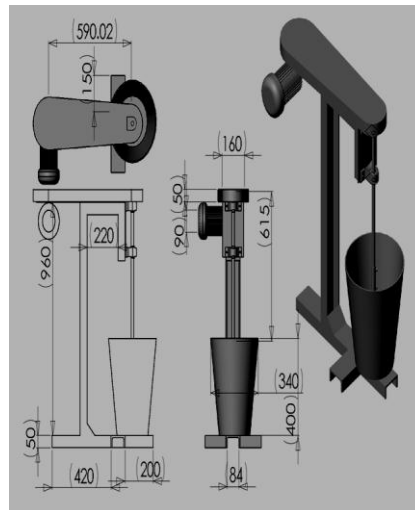

Fig: 14 multiply views

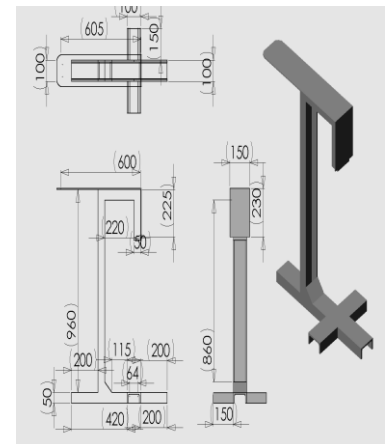

Fig 15 frame

## CUSTOMER AND ENGINEERING REQUIREMENTS

### Requirement

In product development and process optimization, a requirement is a singular documented need that a particular design, product or process must be able to perform. It is most commonly used in a formal sense in systems engineering, software engineering or enterprise engineering. It is a statement that identifies a necessary attribute, capability, characteristic, or quality of a system for it to have value and utility to a customer, organization, internal user, or other stakeholder. A requirements specification (often imprecisely referred to as the **spec**. Because there are different sorts of specification) refers to an explicit set of requirements to be satisfied by a design, product or services. In the classical engineering approach, sets of requirements are used as inputs into the design stages of products development. Requirements are also an important input into the verification process, since tests should trace back to specific requirements. Requirements show what elements and functions are necessary for the particular project. This is reflected in the waterfall model of the software life-cycle. However, when iterative methods of software development or agile methods are used, the system requirements are incrementally developed in parallel with design and implementation.

### Gathering Customer Requirements

In the mid-1980's managers began to recognize that being technology-driven –the practice of creating new technologies and then trying to find markets for them – was an inefficient approach to managing innovation and

led to many failed efforts. As a result, momentum shifted to the customer-drive movement, which required managers to first understand what the customer wanted before investing in the creation of a new product or service. As part of this movement, managers sought needed inputs from customers and these inputs became known as “customer requirements”. As the process for getting these inputs evolved, it became popular –and is still today – to capture just what the customer says and to use that information as an input into the innovation process. This approach is often referred to as capturing the “voice-of-the-customer”. Logically, focusing on the “voice-of-the-customer” makes good sense, as it requires companies to listen closely to customers.

### ENGINEERING MANAGEMENT

Engineering managers oversee 4-P's people, projects, products, and processes. Overseeing manufacturing and production standards, working with creative engineers and generating technical documentation are just some of the responsibilities. Specialized knowledge and management practices geared toward the engineering environment help to enrich an engineering managers' toolbox to deal with the 4- P's with as much savvy as technical issues.

### Project

Every project has people in several different roles. The central person is the project manager. He or she plans the project, pulls the team together, communicates with everyone, and makes sure that the job gets done right. Part of the project manager's job is to explain to

everyone else what his or her role on the project is and how it is crucial to project success. The project manager must communicate with everyone and persuade each person to do his or her part.

## PROJECT MANAGEMENT

Project management Tasks for the project were divided equally among the six team members. Modeling and Simulation was completed by Rufus and Ben, while Samuel, Toyi others managed the tasks and deadlines of the project. Many of the experiments were conducted with at least two members present and each team member was responsible for taking observations and developing design ideas. Online Regular team meetings were held to discuss shortcomings and progress of the project. A Henry Gantt chart can be found in Appendix A displaying the Individual task assignments and deadlines. This chart was used to guide the team and assure timely completion of the project. Each experiment provided insight for the project and so Gantt chart was updated regularly with new tasks to accomplish.

## COMPUTER AIDED DESIGN

CAD began as an electronic drafting board, a replacement of the traditional paper and pencil drafting method. Over the years it has evolved into a sophisticated surface and solid modeling tool. Not only can products be represented precisely as solid models, factory shop floors can also be modeled and simulated in 3D. It is an indispensable tool to modern engineers. Engineers use CAD to create two- and three- dimensional drawings, such as those for automobile and airplane parts, floor plans, and maps and machine assembly. While it may be faster for an engineer to create an initial drawing by hand, it is much more efficient to change and adjust drawings by computer. In the design stage, drafting and computer graphics techniques are combined to produce models of different parts. i. Using a computer to perform the six-step 'art-to-part' process: The first two steps in this process are the use of sketching software to capture the initial design ideas and to produce accurate engineering drawings. Next, engineers use analysis software to ensure that the part is strong enough. Step five is the production of a prototype, or model. In the final step the CAM software controls the machine that produces the part, during the design of the machine and the drafting, software was used to draw the orthogonal views, Isometric views, exploded drawings fig; 1 shows the detailed drawing of the machine, modeling and simulation was done before the commencement of the fabrication processes.

## MODELING

Modeling is the process of producing a model; a model is a representation of the construction and working of some system of interest fig;2-7, 10-13. A model is similar to but simpler than the system it represents. One purpose of a model is to enable the analyst to predict the effect of changes to the system. On the one hand, a model should be a close approximation to the real system and incorporate most of its salient features. On the other hand, it should not be so complex that it is impossible to understand and experiment with it. A good model is a judicious tradeoff between realism and simplicity. Simulation practitioners recommend increasing the complexity of a model iteratively. An important issue in modeling is model validity. Model validation techniques include simulating the model under known input conditions and comparing model output with system output. Generally, a model intended for a simulation study is a mathematical model developed with the help of simulation software. Mathematical model classifications include deterministic (input and output variables are fixed values) or stochastic (at least one of the input or output variables is probabilistic); static (time is not taken into account) or dynamic (time-varying interactions among variables are taken into account). Typically, simulation models are stochastic and dynamic.

## SIMULATION

Simulation technology can provide a highly effective means for evaluating the design of a new manufacturing system or proposed modifications to existing systems. This technology can be especially useful in supporting agility, sustainability, supply chain integration, as well as the development of new advanced processes. Manufacturing simulations are often used as measurement tools that predict the behavior and performance of systems that have not yet been implemented, or to determine theoretical capabilities of existing systems. Simulations are essentially experiments. As defined in Jerry Banks Handbook of Simulation, a simulation is: "...the imitation of the operation of a real-world process or system over time. Simulation involves the generation of an artificial history of the system and the observation of that artificial history to draw inferences concerning the operational characteristics of the real system that is represented. Simulation is an indispensable problem-solving methodology for the solution of many real-world problems. Simulation is used to describe and analyze the behavior of a system, ask what-if questions about the real system, and aid in the design of real

systems. Both existing and conceptual systems can be modeled with simulation.” figure 7-9

## PRODUCT

All products start out as virtual products fig1. That is ideas and information about what the physical product should be. These virtual products are then realized in physical form through the manufacturing process. The manufacturing of products can be divided into three phases: making the first one, ramp-up, and making the rest. “Making the first one” entailed getting a physical product that embodied the ideas of what the virtual product was required to accomplish. Ramp-up and production (“making the rest”) relied on the premise that these products would be close enough to the first one so as to be functionally and physically equivalent. The accuracy of that premise varies widely even today, which is why expensive quality audit inspection processes are required of the actual product instances themselves

## VIRTUAL PRODUCTS

There are a myriad number of uses that can be made of the virtual product created through PSM(Product Specification Management consists).. In the manufacturing or build phase, the “as-built” virtual product is immediately available and can be transmitted to customers and other parties in the supply chain who need the information about the product to assure themselves that the product is actually being created to the required specifications and Customer requirements

## SUSTAINABILITY –

Simulation technology has been a significant tool for improving manufacturing operations in the past; but its focus has been on lowering costs, improving productivity and quality, and reducing time to market for new products. Sustainable manufacturing includes the integration of processes, decision-making and the environmental concerns of an active industrial system to achieve economic growth, without destroying precious resources or the environment. Sustainability applies to the entire life cycle of a product. It involves selection of materials, extraction of those materials, of parts, assembly methods, retailing, product use, recycling, recovery, and disposal will need to occur if simulation is to be applied successfully to sustainability. Manufacturers will need to focus on issues that they have not been concerned with before ,.

## PRODUCTIVITY

Business Managers, see productivity not only as a measure of efficiency, but also connotes effectiveness and performance of individual organizations. For them, productivity would incorporate quality of output, workmanship, adherence to standards, absence of complaints, customer satisfaction, etc (Udo-Aka, 1983). The administrator is more concerned with organizational effectiveness, while the industrial engineer focuses more on those factors which are more operational and quantifiable, work measurement and performance standards (Adekoya, 1989). Productivity can be computed for a firm, industrial group, the entire industrial sector or the economy as a whole. It measures the level of efficiency at which scarce resources are being utilized. Higher or increasing productivity will, therefore, mean either getting more output with the same level of input or the same level of output with less input. Let us look at the sub-concepts.

**TOTAL-FACTOR PRODUCTIVITY:** This is the ratio of output to the aggregate measure of the inputs of all the factors of production. Theoretically, this is the true measure of productivity as it incorporates the contribution of all the factor inputs. Factor Productivity is often seen as the real driver of growth within an economy and studies reveal that whilst labour and investment are important contributors, Total Factor Productivity may account for up to 60% of growth within economies Technology growth and efficiency are regarded as two of the biggest sub-sections of Total Factor Productivity, the former possessing "special" inherent features such as positive externalities and non-rivalness which enhance its position as a driver of economic growth

## MANUFACTURING

Manufacturing is the means by which the technical and industrial capability of a nation is harnessed to transform innovative designs into well-made products that meet customer needs. This activity occurs through the action of an integrated network that links many different participants with the goals of developing, making, and selling useful things. Manufacturing is the conversion of raw materials into desired end products. The word derives from two Latin roots meaning hand and make. Manufacturing, in the broad sense, begins during the design phase when judgments are made concerning part

geometry, tolerances, material choices, and so on. Manufacturing operations start with manufacturing planning activities and with the acquisition of required resources, such as process equipment and raw materials. The manufacturing function extends throughout a number of activities of design and production to the distribution of the end product and, as necessary, life cycle support. Modern manufacturing operations can be viewed as having six principal components: materials being processed, process equipment (machines), manufacturing methods, equipment calibration and maintenance, skilled workers and technicians, and enabling resources. There are three distinct categories of manufacturing:

- **Discrete item manufacturing**, which encompasses the many different processes that bestow physical shape and structure to materials as they are fashioned into products. These processes can be grouped into families, known as unit manufacturing processes, which are used throughout manufacturing.
- **Continuous materials processing**, which is characterized by a continuous production of materials for use in other manufacturing processes or products. Typical processes include base metals production, chemical processing, and web handling.
- **Micro- and nano-fabrication**, which refers to the creation of small physical structures with a characteristic scale size of microns (millionths of a meter) or less. This category of manufacturing is essential to the semiconductor and mechatronics industry. It is emerging as very important for the next-generation manufacturing processes.

#### **Modern Manufacturing**

Manufacturing technologies address the capabilities to design and to create products, and to manage that overall process. Product quality and reliability, responsiveness to customer demands, increased labor productivity, and efficient use of capital were the primary areas that leading manufacturing companies throughout the world emphasized during the past decade to respond to the challenge of global competitiveness. As a consequence of these trends, leading manufacturing organizations are flexible in management and labor practices, develop and produce virtually defect-free products quickly (supported with global customer service) in response to opportunities, and employ a smaller work force possessing multidisciplinary skills. These companies have an optimal balance of automated and manual operations. To meet these challenges, the manufacturing practices must be continually evaluated and strategically employed. In addition, manufacturing

firms must cope with design processes (e.g., using customers' requirements and expectations to develop engineering specifications, and then designing component

#### **DISCUSSIONS AND CONCLUSION**

It is general knowledge that those who are engaged in agriculture are the poor in comparison with those who are engaged in other sector of the economy in Nigeria that is to say their standard of living is so low that shortage of funds to enable them facilities has been a major handicap in the development .

Investigation shows that the few available small scale processing equipment are not very efficient..This lack of efficiency small scale processing equipment to farmers has increased the inability of their farming activities.

**Agricultural productivity** is measured as the ratio of agricultural outputs to agricultural inputs. While individual products are usually measured by weight, their varying densities make measuring overall agricultural output difficult. Therefore, output is usually measured as the market value of final output, which excludes intermediate products such as corn feed used in the meat industry. This output value may be compared to many different types of inputs such as labour and land (yield). This measure of agricultural productivity was established to remedy the shortcomings of the partial measures of productivity; notably that it is often hard to identify the factors cause them to change. Changes in Total Factor productivity are usually attributed to technological improvements. Today It is rare to find an engineering design, or architectural firm of any size without a working CAD system, running on a personal computer or workstation. Many of the individual task within the overall design process can be performed using a computer. As each of these tasks is made more efficient the efficiency of overall process increases as well. Computer aided design uses the mathematical and graphic processing power of the computer to assist the engineer in the creation,modification,analys, and designs many factors have contributed to CAD technology becoming the necessary tool in the engineering technical data base, CAD combines the characteristic of designer and computer that are best applicable to the design process, the combination of human creativity with computer technology provides the design efficiency that has made CAD such as popular design tool. CAD Has allowed the designer to by pass much of the Manuel drafting and analysis that previously required, making the design process flow more smoothly and much more efficiently.



Simulation tools enable us to be creative and to quickly test new ideas that would be much more difficult, time-consuming, and expensive to test in the lab. (Jeffrey D. Wilson, Nasa Glenn Research Center) It also help us reduce cost and time-to-market by testing our designs on the computer rather than in the field. It is against this background that our research theme was derived and the advantages are as following

**COST EFFECTIVE:** The cost of this machine is very low and can be affordable by both poor and rich, it requires little or no frequent maintenance

**INCREASE IN PRODUCTIVITY** (level) increased productivity lead to increases in wealth of a nation. Productivity of feed mixing will help in no small measure to increase in productivity level of a nation which will increase value addition to GDP

**POVERTY REDUCTION AND JOB CREATION:** It help to create job for people since it is affordable and this reduce in rural –urban migration

**ENCOURAGE DIRECT AND INDIRECT INVESTMENT:** It will help in the expansion of domestic and international trade. It will equally increase rapid national economic growth and development.

**ENCOURAGE INNOVATION THROUGH USAGE AND OBSERVATION BY LOCAL FABRICATORS .** Since the machine is fabricated locally, the usage will help local fabricator to innovate or improve in their fabrication. By so doing, it will help in the living standard of rural people Customer and Engineering Requirements.

**REDUCTION IN UNEMPLOYMENT.** The reduction of unemployment is of two fold which includes those fabricating machine and those using the machine will be the beneficiaries

**ENCOURAGE DIRECT AND INDIRECT INVESTMENT,** It will help in no small measure in the creation of industries for oil processing manufacturing and other processing ventures. It will equally increase rapid national economic growth and development.

**ECONOMIC DEVELOPMENT AND INDUSTRIALIZATION.** It will help in economic development and industrialization because it will lead to the creation of a new investment culture, wealth creation and increased economic and social welfare.

## CONCLUSION

Many of the individual tasks within the overall design process can be performed using a computer. As each of these tasks is made more efficient, the efficiency of the overall process increases as well. The computer is well suited to design in four areas, which correspond to the

latter four stages of the general design process. Computers function in the design process through geometric modeling capabilities, engineering analysis calculations, testing procedures, and automated drafting, from the result of testing and affordability in term of cost, it can be concluded that the project is successful, therefore software design should be encouraged in our institution of higher learning base on the following facts, long product development, countless trial and error, and accountability and limited profitability

## REFERENCE

- [1] Osokam Shadrach Onygu, Ogbanga Ibifuro, Monday Nsikan Idung and Thompson Aguheva, *Design and fabrication of an Industrial Poultry feed Tumble mixer* Leonardo Electronic Journal of Practices and Technologies Issue 20, January 2012
- [2] Engr. R. O. Chime, Engr. S. I. Ukwuaba, Engr. Ukwu Nwachukwu (2013) *Design Modelling and Simulation of a Screw press Expeller for palm kernel oil extraction* [International Engineering Conference, Exhibition and Annual General meeting] NSE Proceedings,
- [3] R. S. Khurmi and J. K. Gupta; *Theory Of Machines*, S. Chand and Company Ltd.
- [4] R. S. Khurmi and J. K. Gupta; *Machine Design*, S. Chand and Company Ltd.
- [5] <http://www.en.wikipedia.org/wiki/feedmixer>
- [6] Ashby F.M. Jones R.B.H., *Engineering materials; An Introduction to Their properties and Application*, Second Edition, Butterworth Heinemann, oxford 2002
- [7] Olaoye, J.O. and Babatunde O.O.; (Development and Testing of a milled Shea Nut mixer) *Journal Food Science Technology* Vol.38 N.5 pp.475, 2001
- [8] Law, A. M., and M. G. McComas. 1991. *Secrets of Successful Simulation Studies*, Proceedings of the 1991 Winter Simulation Conference, ed. J. M. Charnes, D. M. Morrice, D. T. Brunner, and J. J. Swain, 21–27. Institute of Electrical and Electronics Engineers, Piscataway, New Jersey
- [9] Koya O.A and Faborode M.O (2005) *Mathematical modelling of palm fruit cracking based on Hertz's Theory* Bios stems Engineering, Vol.91 No.4 pp 471– 7
- [10] Fishwick, P. A. 1995. *Simulation Model Design and Execution: Building Digital Worlds*, –Hall. Freund, J. E. 1992. *Mathematical Statistics*, Fifth Edition,
- [11] [http://www.simetric.co.uk/si\\_mater.htm](http://www.simetric.co.uk/si_mater.htm). Mass, Weight, Density or specific Gravity of bulk material

- [12] Shigley J. E. and Mischke C. R., "Mechanical Engineering Design," McGraw Hill Companies, Inc. 6<sup>th</sup> Edition, New York, U.S.A, 2001
- [13] Mechanical Engineers' Handbook, 2nd ed., Edited By Myer Kutz.
- [14] Ashok Kumar Gupta Dr. Vandana Somkuwar (2014) Spiral Gevel Gear And Development Generation And Simulation Of Meshing And Too Th Contact Analysis (TCA)
- [15] Mark T.Holtzapple W.Dan Reece "Fundamental of Engineering"Texas A&M University
- [15] Amber Beck, Nick Dalbec, James Zoss(2005) Design of a manually operated mixing Machine for Shea Butter application
- [16] Productivity in Nigeria, Proceedings of a National Conference, Edited by Osoba, A.M., Page 75
- [17] Project management for small business made easy / by Sid Kemp. p. cm. ISBN 1-932531-77-7 (alk. paper)
- [18] Akinlo, E. A. (1996), Improving the Performance of the Nigerian Manufacturing Sub-Sector after Adjustment, The Nigerian Journal of Economic and Social Studies, Page 9.
- [19]Maynard's Industrial Engineering Handbook
- [20] Babyak, Rechar J.(2003) *Visionary Design*. Appliance Manufacturer
- [21] Dr. Michael Grieve.(2009) Dual Manufacturing Both Real and Virtual Products, NASA MSFC/University of Iowa
- [22] C.M.Anyanwu. (1983)Production in the Nigerian Manufacturing Industry
- [23] Oloko, O. (1983), Factors in Labour Productivity, Proceeding of a National Conference on Productivity, Edited by Osoba, A.M. Page 7.
- [24] Udo-Aka, U. (1983), Measuring productivity: Issues and Problems in Productivity in Nigeria, Proceedings of a National Conference, Edited by Osoba, A.M., Page 75.
- [25] Requirement Wikipedia, the free encyclopedia
- [26]Anthony W. Ulwick[2002] Turn Customer Input Into Innovation, Candace Carlson (2010) Improving Productivity in Mold Design and Fabrication
- [27] Industrial Engineering handBook fifth Edition Edited by KJELL B. zandian Co-sponsors by JMA ,INC.
- [28] Bliumin, I. G. Kritika burzhuaznoi politicheskoi ekonomii, vol. 1. Moscow, 1962.
- [29] Nikitin, S. M. Teorii Stoimosti I Ikh Evoliutsii. Moscow, 1970
- [30] The Great Soviet Encyclopedia, 3rd Edition (1970-1979). © 2010 The Gale Group, Inc. All rights reserved.
- [31] Wikipedia, the free encyclopedia

Appendix A

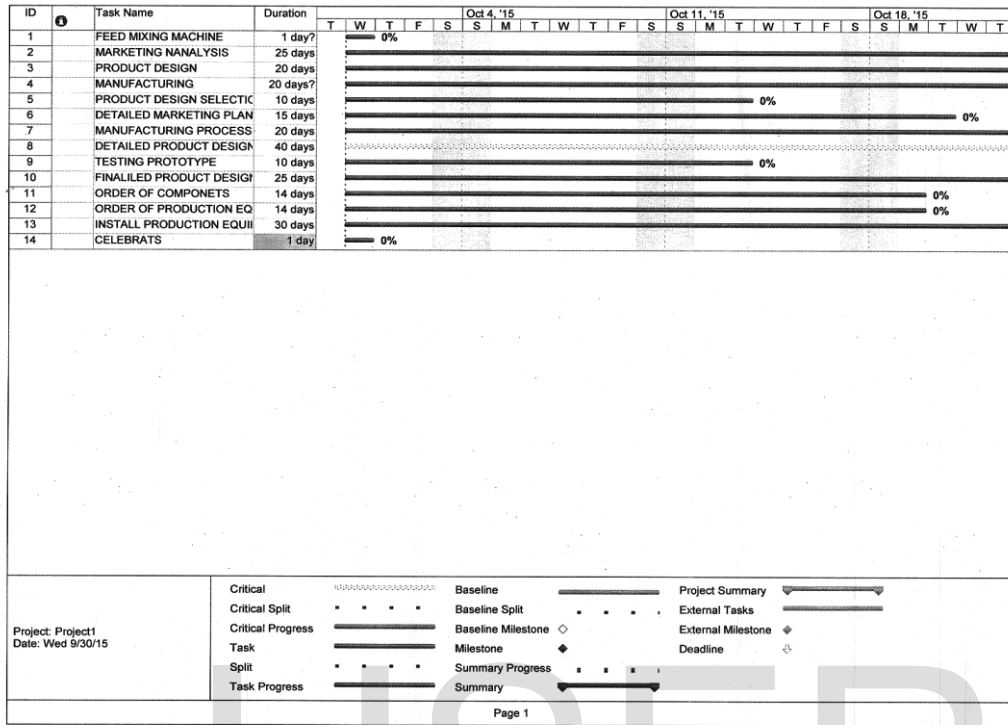

Tracking Gantt

APPENDIX B

